

**MJ series 1.3-2.0t 3-wheel electric forklift**

Specification	1	Model		MJ13	MJ16	MJ18	MJ20	
	2	Controller Type		ZAPI AC				
	3	Rated capacity	kg	1300	1600	1800	2000	
	4	Load centre	mm	500	500	500	500	
	5	Lifting height	mm	3000	3000	3000	3000	
	6	Free lifting height	mm	120	120	120	120	
Dimensions	7	Fork size	L×W×T	mm	920×100×35	920×100×35	920×100×35	920×100×35
	8	Tilting angle	F/R (α°/β°)	Deg	6.5°/6.5°	6.5°/6.5°	6.5°/6.5°	6.5°/6.5°
	9	Overall Dimension	Length to fork face	mm	1879	1979	1979	2094
			Width	mm	1070	1070	1070	1140
			Height when mast lowered	mm	1975	1975	1975	1975
			Height when mast extended	mm	3980	3980	3980	3980
	11		Height to safeguard	mm	1971	1971	1971	2011
	12							
	13	Turning radius	Min.	mm	1543	1643	1643	1758
	14	Front overhang		mm	371	371	371	371
	15	Tread	F/R	mm	924/186	924/186	924/186	942/186
	16/17	Ground clearance	Min.	mm	90	90	90	90
	18	Wheel base		mm	1300	1400	1400	1515
	19	Fork spread	Min./Max.	mm	200/890	200/890	200/890	200/890
	20	Working aisle width with pallet(Ast)*	1000×1200 crossways	mm	3240	3340	3340	3445
	21		800×1200 lengthways	mm	3364	3464	3464	3579
	22							
	Performance	23	Speed	Travel(Laden)	km/h	13	13	13
Travel(Unladen)				km/h	13	13	13	13
Lifting(Laden)				mm/s	300	290	280	255
Lifting(Unladen)				mm/s	460	445	435	405
24		Gradeability	Laden	%	15	15	15	15
			Unladen	%	15	15	15	15
25		Self weight	Include battery box	kg	2820	3080	3140	3430
26		Tyre	Front×2		18×7-8	18×7-8	18×7-8	200/50-10
			Rear×2		15×4.5-8	15×4.5-8	15×4.5-8	15×4.5-8
27								
Driven	32	Motor	Driven motor	kw	4×2	4×2	4×2	4×2
			Pump motor	kw	9.2	9.2	11	11
	33	Battery	Standard	V/Ah	48/400	48/500	48/500	48/625
34	Operating pressure for attachment		Mpa	14.5	14.5	14.5	17.5	

**MJ series 1.3-2.0t 3-wheel electric forklift mast**

Type	Model	Max. fork height	Overall height				Free lift		Front Overhang	Tilt range		Capacity			
			Lowered	Extended		Without backrest	With backrest	FWD		BWD	Load capacity at 500mm				
				Without backrest	With backrest						Single tire				
			mm	mm	mm	mm	mm	mm		Deg	Deg	1.3t	1.6t	1.8t	2.0t
Wide view 2-stage mast	BM250	2500	1725	3010	3480	120	120	371	6.5	6.5	1300	1600	1800	2000	
	BM270	2700	1825	3210	3680	120	120	371	6.5	6.5	1300	1600	1800	2000	
	BM300	3000	1975	3510	3980	120	120	371	6.5	6.5	1300	1600	1800	2000	
	BM330	3300	2125	3810	4280	120	120	371	6.5	6.5	1300	1600	1800	2000	
	BM350	3500	2225	4010	4480	120	120	371	6.5	6.5	1300	1600	1800	2000	
	BM370	3700	2325	4210	4680	120	120	371	3.5	5	1300	1600	1800	2000	
	BM400	4000	2525	4510	4980	120	120	371	3.5	5	1300	1600	1800	2000	
	BM425	4250	2650	4760	5280	120	120	371	3.5	5	1200	1500	1700	1900	
	BM450	4500	2775	5025	5480	120	120	371	3.5	5	1100	1400	1600	1800	
	BM550	5500	3325	6025	6480	120	120	371	3.5	5	850	1150	1200	1300	
Full free 2-stage mast	BFM250	2500	1725	3010	3465	1230	725	371	6.5	6.5	1300	1600	1800	2000	
	BFM270	2700	1825	3210	3665	1330	825	371	6.5	6.5	1300	1600	1800	2000	
	BFM300	3000	1975	3510	3965	1480	975	371	6.5	6.5	1300	1600	1800	2000	
	BFM330	3300	2125	3810	4265	1630	1125	371	6.5	6.5	1300	1600	1800	2000	
	BFM350	3500	2225	4010	4465	1730	1225	371	6.5	6.5	1300	1600	1800	2000	
	BFM370	3700	2325	4210	4665	1830	1325	371	3.5	5	1300	1600	1800	2000	
	BFM400	4000	2525	4510	4965	2030	1525	371	3.5	5	1300	1600	1800	2000	
Full free 3-stage mast	BTFM335	4350	1975	4860	5330	1460	995	371	3.5	5	1200	1500	1700	1900	
	BTFM450	4500	2025	5010	5480	1515	1045	371	3.5	5	1100	1400	1600	1800	
	BTFM480	4800	2125	5310	5780	1615	1145	371	3.5	5	1000	1300	1500	1550	
	BTFM500	5000	2225	5510	5980	1715	1245	371	3.5	5	950	1250	1450	1500	
	BTFM550	5500	2390	6010	6480	1880	1410	371	3.5	5	850	1150	1200	1300	
	BTFM600	6000	2575	6510	6980	2065	1595	371	3.5	5	750	1050	1100	1200	

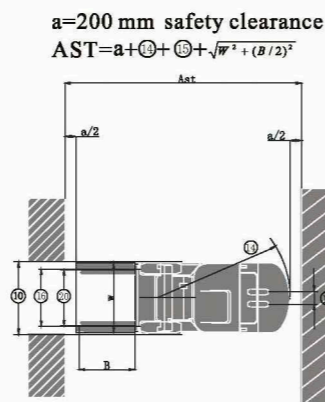
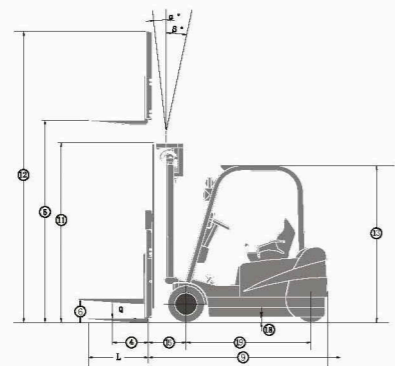

**MJ series  
1.3 - 2.0 tonnes  
3-wheel electric forklift**