

Push/Pull



Let the
forklift
become a
universal
forklift

Functions & Applications

Push/Pull is designed for slipsheet applications requiring high productivity with easy maintenance.

Features

- Excellent driver visibility
- Flexible spacing between both fork planks
- Smooth contact parts ease the damage of slide plate
- Strength and durability to work in demanding applications
- High strength and secure structure
- Simplified hydraulic system
- Smooth operation with the buffering function of cylinder

Push/Pull

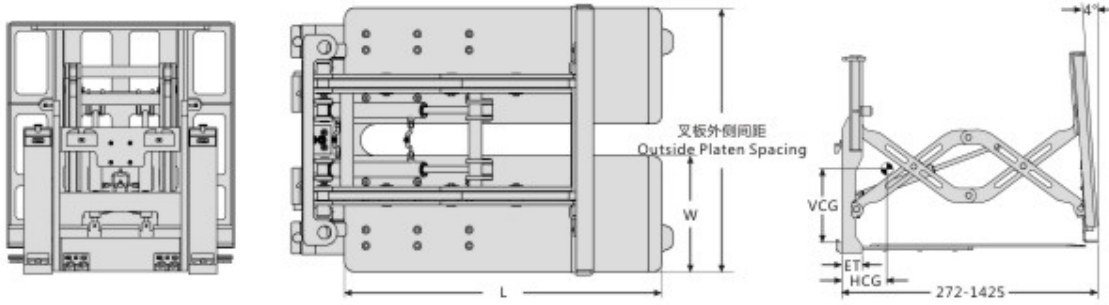

Capacity@ Load Center	Type	Platen Size	Catalog Order No.	Mounting Class	Outside Platen Spacing	Minimum Truck Carriage Width	Vertical Center of Gravity	Weight	Effective Thickness	Horizontal Center of Gravity
(kg@mm)		WXL (mm)		等级	(mm)	(mm)	VCG (mm)	(kg)	ET (mm)	HCG (mm)
Standard										
1600@600		455x1220	TLQ16D-B007	II	1015-1220	915	220	501	165	221
1600@600	Sideshifting	380x1220	TLQ16D-B008	II	865-1065	915	235	479	165	203
1600@600		455x1220	TLQ16D-B009	II	1015-1220	710	225	494	165	224
1600@600	Non-sideshifting	380x1220	TLQ16D-B010	II	865-1065	710	240	472	165	206
1600@600		455x1220	TLQ16D-B011	II	1015-1220	915	225	506	165	221
1600@600	Hyd.Adj.platens&ss	380x1220	TLQ16D-B012	II	865-1065	915	235	483	165	203
1600@600		455x1220	TLQ16D-B013	II	1015-1220	915	210	633	229	257
1600@600	Sheet-Sav Sideshifting	380x1220	TLQ16D-B014	II	865-1065	915	225	603	229	239
1600@600		455x1220	TLQ16D-B015	II	1015-1220	915	215	456	165	231
1600@600	Sideshifting	380x1220	TLQ16D-B016	II	865-1065	915	230	433	165	211
1600@600		455x1220	TLQ16D-B017	II	1015-1220	710	220	449	165	234
1600@600	Non-sideshifting	380x1220	TLQ16D-B018	II	865-1065	710	230	426	165	213
2000@600		455x1220	TLQ20D-B007	II	1015-1220	915	215	515	165	231
2000@600	Sideshifting	380x1220	TLQ20D-B008	II	865-1065	915	230	490	165	211
2000@600		455x1220	TLQ20D-B009	II	1015-1220	710	220	508	165	234
2000@600	Non-sideshifting	380x1220	TLQ20D-B010	II	865-1065	710	230	483	165	213
2000@600		455x1220	TLQ20D-B011	II	1015-1220	915	215	518	165	231
2000@600	Hyd.Adj.platens&ss	380x1220	TLQ20D-B012	II	865-1065	915	230	494	165	211
2000@600		455x1220	TLQ20D-B013	II	1015-1220	915	210	633	229	257
2000@600	Sheet-Sav Sideshifting	380x1220	TLQ20D-B014	II	865-1065	915	225	603	229	239
2000@600		455x1220	TLQ20D-B015	II	1015-1220	915	210	469	165	241
2000@600	Sideshifting	380x1220	TLQ20D-B016	II	865-1065	915	225	445	165	221
2000@600		455x1220	TLQ20D-B017	II	1015-1220	710	210	463	165	244
2000@600	Non-sideshifting	380x1220	TLQ20D-B018	II	865-1065	710	225	438	165	224

Obtain the actual capacity of the forklift and attachments from the forklift manufacturer.

One set additional oil circuit required for Non-sideshifting, two sets additional oil circuit required for sideshifting.